

P/N	MODEL#	PHASE	VOLTAGE	SLACK ROPE SR	OVER LOAD OL	TOP LIMIT TK	WEIGHT
9005	SC1000	1PH	208V				99
9006	SC1000	1PH	208V	✓			103
9007	SC1000	1PH	208V	✓	✓	✓	103
9008	SC1000	1PH	208V		✓		99
9009	SC1000	1PH	208V	✓	✓		103
9015	SC1500	1PH	208V				101
9016	SC1500	1PH	208V	✓			105
9017	SC1500	1PH	208V	✓	✓	✓	105
9018	SC1500	1PH	208V		✓		101
9019	SC1500	1PH	208V	✓	✓		105
9025	SC1500A						89
9026	SC1500A			✓			93
9035	SC1500	3PH	208V				101
9036	SC1500	3PH	208V	✓			105
9037	SC1500	3PH	208V	✓	✓	✓	105
9038	SC1500	3PH	208V		✓		101
9039	SC1500	3PH	208V	✓	✓		105
9045	SC1000	1PH	110V				99
9046	SC1000	1PH	110V	✓			103
9048	SC1000	1PH	110V		✓		99
9049	SC1000	1PH	110V	✓	✓		103

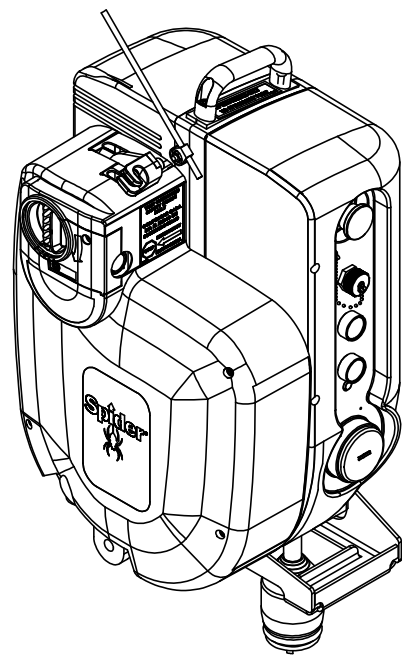

HOIST:SC1000;1000LB:W/QS
9005R
WEIGHT: 99 LB

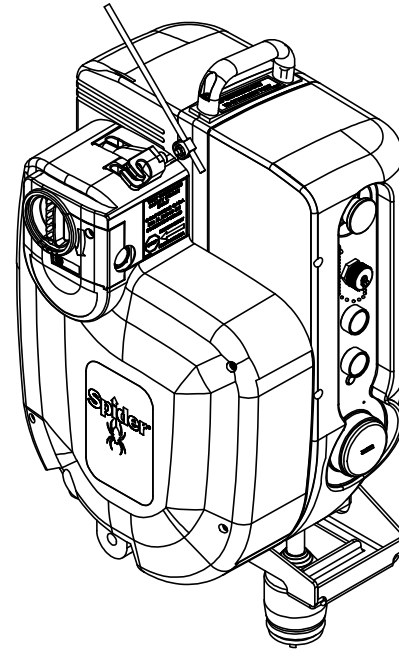

HOIST:SC1500:1PH
9015R
WEIGHT: 101 LB

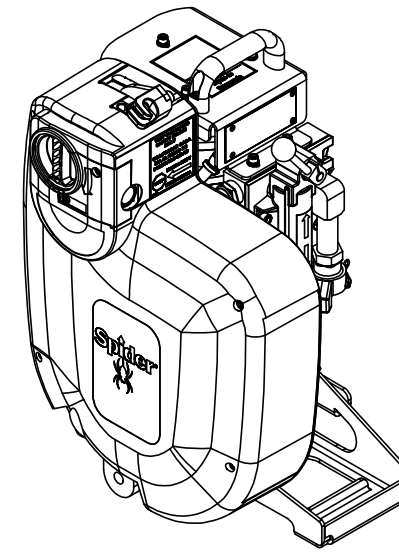

HOIST:SCA:750-1500LB
9025R
WEIGHT: 89 LB

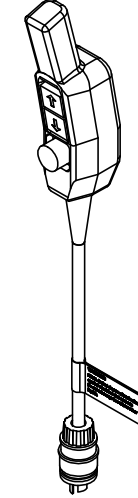

REMOTE_CTRL:SC/PC3 ASSY
709854-XXR
WEIGHT: -5 = 1.5 LB
-100 = 12 lb

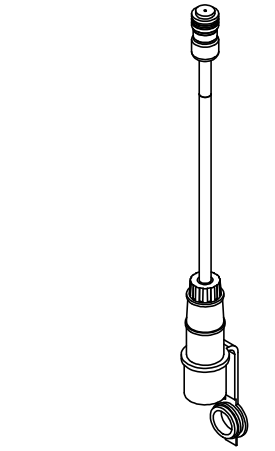

ADAPTER:REMOTE:ZMAC1000 ASSY
700908-1R
WEIGHT: 1 LB

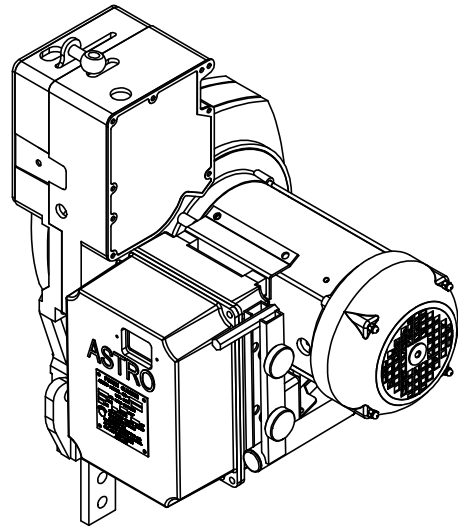

ASTRO B:1PH 220V/60HZ:1.5HP
90.982-1500R
WEIGHT: 136 LB

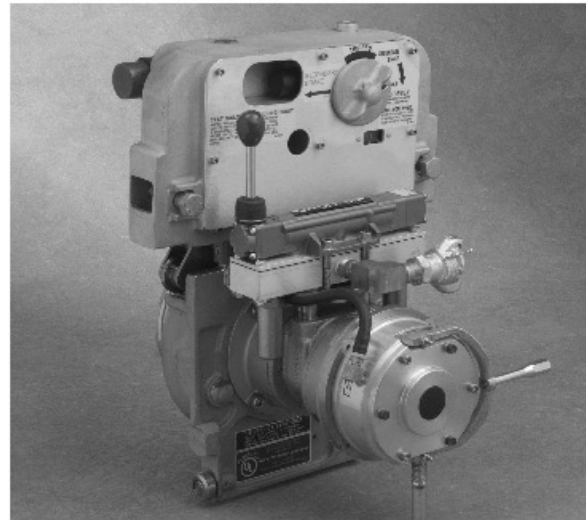

HOIST:AIR:W/O SLCKWR/FRAME
SC30R
WEIGHT: 115 LB

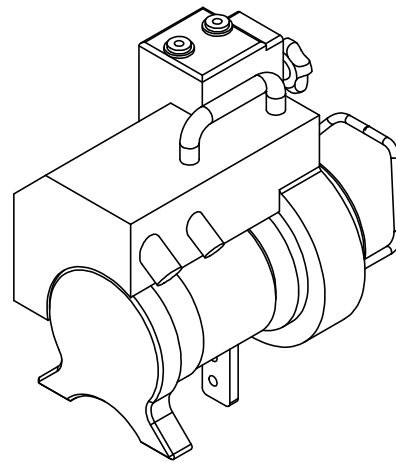

HOIST:ZMAC1000:CAPACITY
700783-1R
WEIGHT: 72 LB

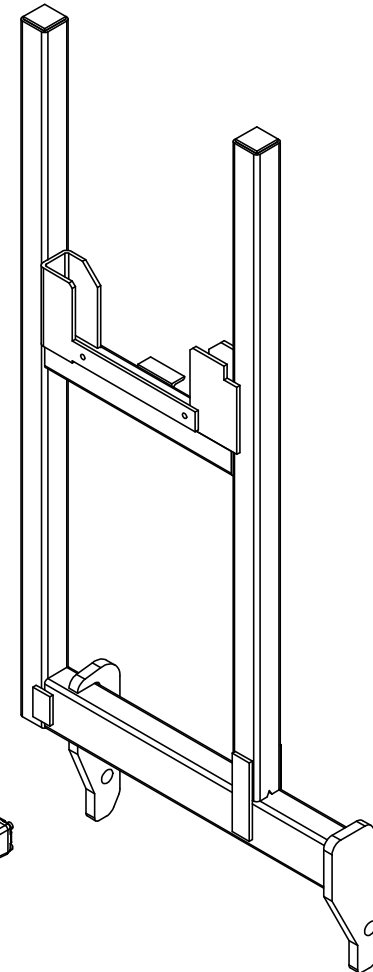

STIRRUP FRAME ASSY:LONG
BB-002R
WEIGHT: 27 LB

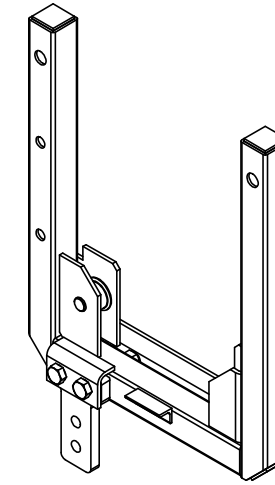

STIRRUP FRAME ASSY:SHORT
BB-004R
WEIGHT: 13.5 LB

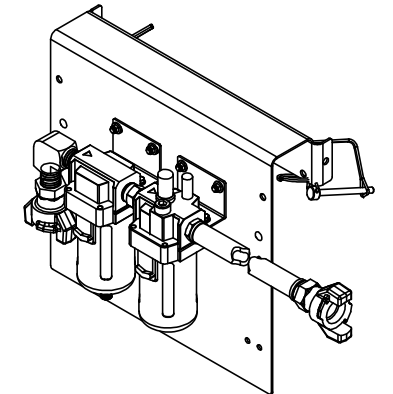

FILTER/LUBRICATR ASSY:PC1/SC30
8-0108R (706126-1)
WEIGHT: 7 LB

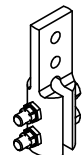

ADAPTER:HOIST:20 DEG.:W/HRDWRE
8-0406R
WEIGHT: 3 LB



ADAPTER:HOIST:90 DEG.:W/HRDWRE
8-0278R
WEIGHT: 3 LB

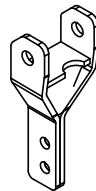

ADAPTER:STIRRUP:ZMAC1000
700956-1R
WEIGHT: 3 LB

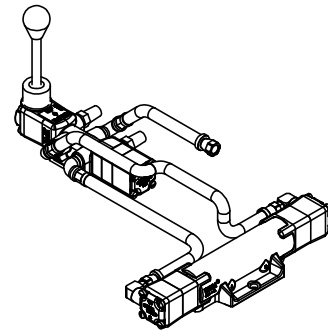

REMOTE CONT.ASSY:ZMAC AIR
701303-10R
WEIGHT: 6 LB

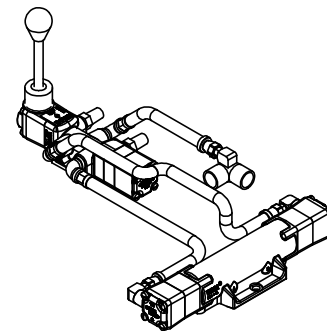

REMOTE CONTROL ASSY:AIR:
9-61-XR
WEIGHT: -- LB

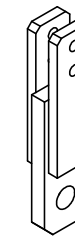

STIRRUP BAR:ZEMLIN ADAPTER
701464-1R
WEIGHT: 8 LB

A		8697-S		2017/NOV/09		TSM	JTA
REV.	ECO	DATE	BY	CHK			
THIRD ANGLE PROJECTION	DRWN	DATE	TITLE				
	TSM	2017/06/23	HOIST PARTS				
		DWG. NO. 721281		REV A			
PROPRIETARY AND CONFIDENTIAL THIS DRAWING IS THE PROPERTY OF SPIDER L.L.C. AND IS NOT TO BE COPIED OR REPRODUCED WITHOUT WRITTEN CONSENT OF SPIDER L.L.C.		SHEET NO. D		SCALE 1:4		SHEET 1 OF 1	