

## Spider Glazier 2200

The Spider Glazier 2200 is a mobile, counterweighted lifting solution for challenging curtain wall applications, providing optimum safety and productivity on high elevation jobsites.

Fully integrated suspended access manufacturing and engineering

Highly specialized design and support expertise

Custom engineered solutions that benefit from complex local safety code expertise

Certified Quality Systems

Investment in operational excellence to drive reliability and consistency across the Americas

24/7 technical support



SPIDER GLAZIER 2200

Global presence with 24 rental and sales locations in the Americas



### With nearly seven decades of knowledge and experience

in putting people to work at height safely and productively, Spider now offers a mobile material lifting solution for your most complex curtain wall applications.

- Lift large loads with the high capacity of 2,150 lbs.
- Increased productivity with hoist speed up to 70 fpm and variable frequency drive
- Precise panel positioning by fine tune adjustments of pendant controls with soft start and stop
- Optimal flexibility with variable outreach ranging from 18 in. to 4 ft and adjustable boom height of up to 117 in.
- Easy set-up and repositioning with quick set adjustable tie-backs, standard Spider counterweights, and heavy-duty, low-profile casters
- Maximized uptime with rapid delivery, service, and repair from 24 branches in the Americas

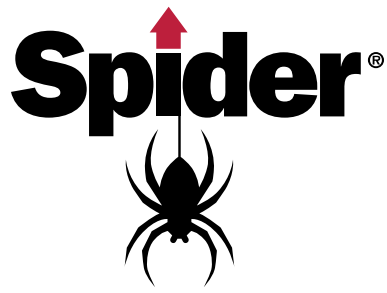

## Spider Glazier 2200

Engineered with curtain walling challenges in mind, the Spider Glazier 2200 simultaneously delivers mobility, high lifting capacity at swift speeds, and precise positioning to your jobsite along with optimal safety and code compliance.

### COMPLIES WITH:

ANSI / ASSE A10.5-2006  
ASME B30.17-2006  
OSHA 1926.552

### FEATURES:

Improved site safety with a material hoist that incorporates both overload and overspeed protections

Top limit switch stops load at upper limit.

Tieback locking device eliminates the need for some fist grips.

Steering handle repositions hoist without removal of counterweights.

Passive wire winder holds 300 ft of 3/8 in. wire rope.

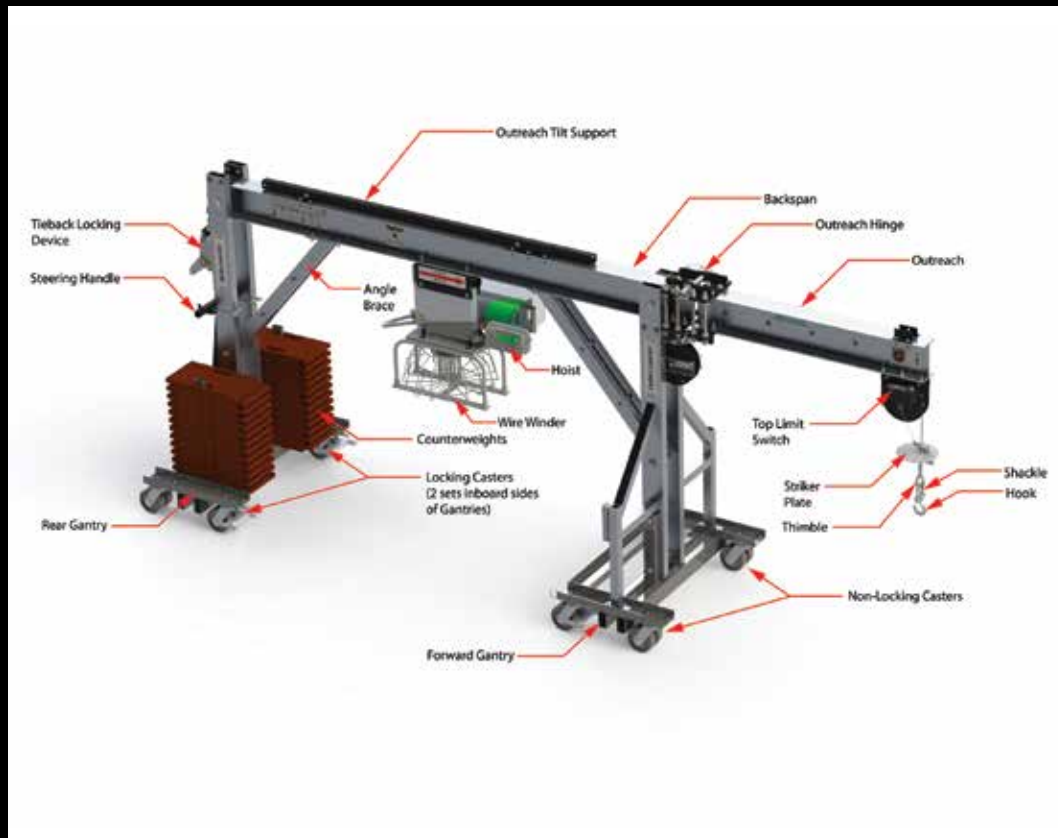

We listen to our customers and continually develop new products with improved features based on your requests.

