

Ring Girder Rollers (4963-01, -02, -03)

Steel construction with wheel as shown below, shackle for tieback and suspended load; For use on floating top petroleum and chemical storage tanks

Key Features:

- Heavy duty steel construction
- Choices of wheel size and material to meet site needs
- Built by Spider in the USA

4963-01 features an 8 in. O.D. x 3 in. (203 x 76 mm) polyurethane wheel with bushings for easy transfer along girder.

4963-02 features a 3 1/2 in. O.D. x 3 1/4 in. (89 x 83 mm) non-marking plastic wheel.

4963-03 features a steel wheel and is used when height between roller and eyebolt is critical. 2 in. (51 mm) wheel with 1 in. (25 mm) flanges keeps the roller tracking on the girder.

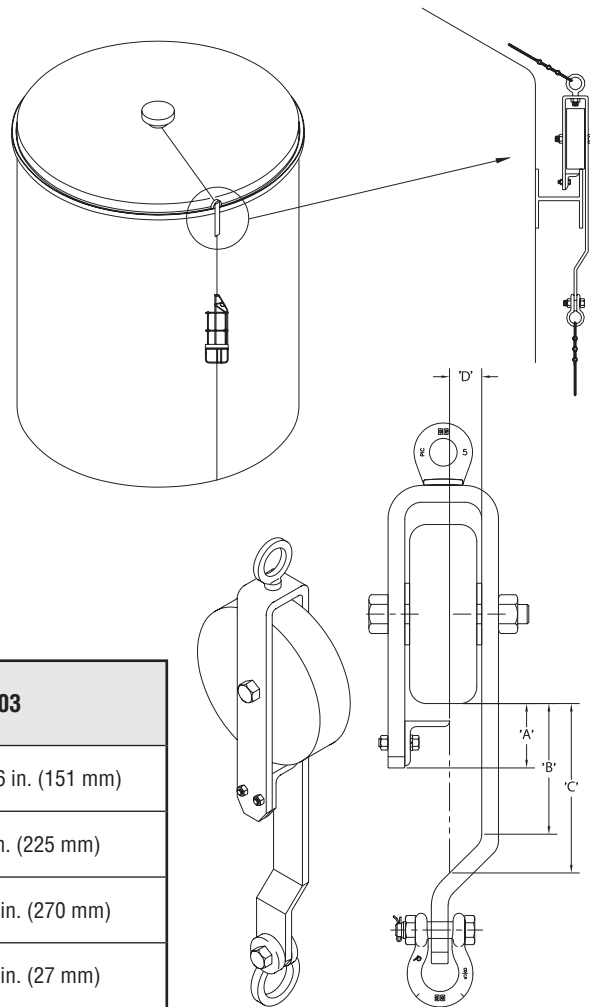

	4963-01	4963-02	4963-03
A	2 7/8 in. (73 mm)	5 1/8 in. (130 mm)	5 15/16 in. (151 mm)
B	5 13/16 in. (148 mm)	8 1/16 in. (205 mm)	8 7/8 in. (225 mm)
C	7 9/16 in. (192 mm)	9 13/16 in. (249 mm)	10 5/8 in. (270 mm)
D	1 7/16 in. (37 mm)	1 7/16 in. (37 mm)	1 1/16 in. (27 mm)

Specifications:	4963-01	4963-02	4963-03
Load/Capacity:	1,000 lb (453.6 kg)	1,000 lb (453.6 kg)	1,000 lb (453.6 kg)
Wheel Dimensions:	8 in. (203 mm)	3 1/2 in. (89 mm)	2 in. (51 mm)
Weight:	30.5 lb (13.9 kg)	25.5 lb (11.6 kg)	25.5 lb (11.6 kg)
Frame:	25.3 x 2.5 x 7 in. (643 x 64 x 178 mm)	25.3 x 2.5 x 7 in. (643 x 64 x 178 mm)	25.3 x 2.5 x 7 in. (643 x 64 x 178 mm)
Construction:	Steel w/ polyurethane wheel	Steel w/ plastic wheel	Steel w/ steel wheel