

# Tank Top Roller–Pin Style (700525-1)

**Steel roller with shackle for tieback and suspended load;  
Effective for rigid top petroleum and other storage tanks**

## Key Features:

- Heavy duty steel construction
- Fully sealed bearing allows both shackles to pivot freely
- Pivoting shackles aid easy rolling
- Capped ends prevent entry of debris into shaft to prolong device life
- Sealed bearing makes rolling smooth and easy
- Sealed bearing does not require lubrication
- Designed for corrosive environments
- Extensive product labels make installation goof-proof
- Built by Spider in the USA

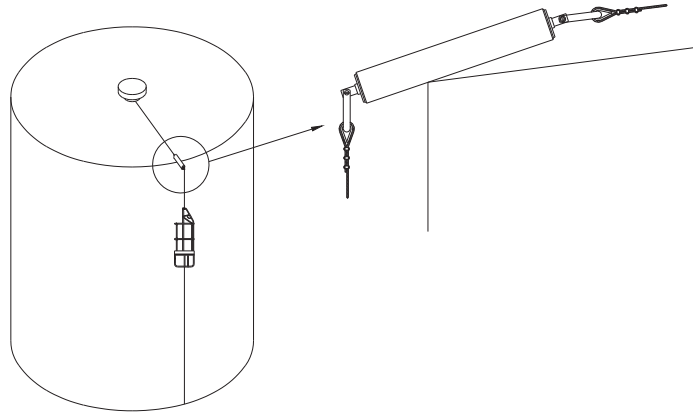

<b>Specifications:</b>	<b>700525-1</b>
<b>Load/Capacity:</b>	Maximum 1,500 lbs. (680.4 kg)
<b>Dimensions:</b>	41 in. (1,041 mm) long x 4 in. (102 mm) o.d.
<b>Weight:</b>	46 lbs. (20.9 kg)
<b>Outreach:</b>	12 in. (304 mm) from edge of tank
<b>Construction:</b>	Steel

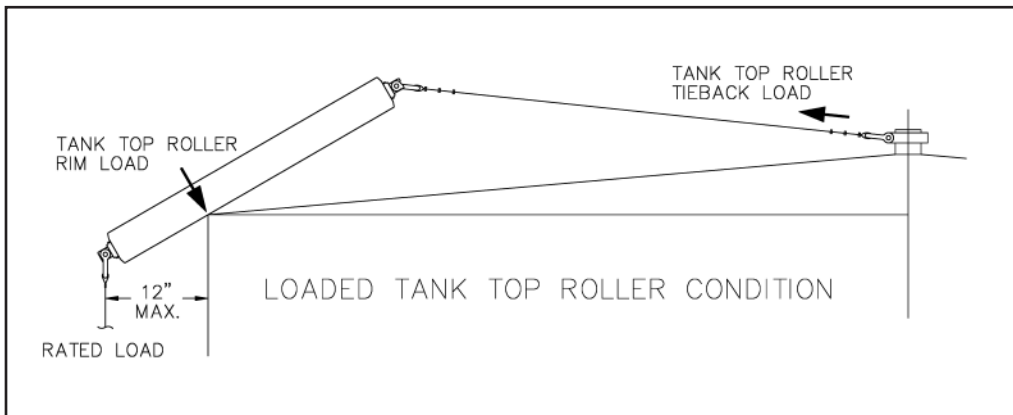
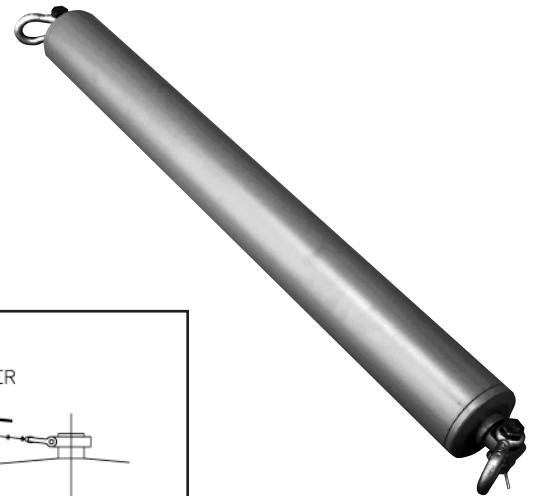

**Protect your investment!**

**Use hoist covers on page 139.**