

## I-Beam Roller (SA-1003 & SA-1003-22)

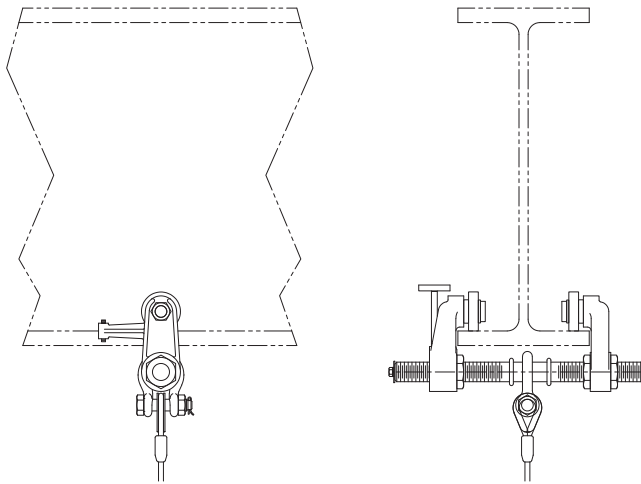
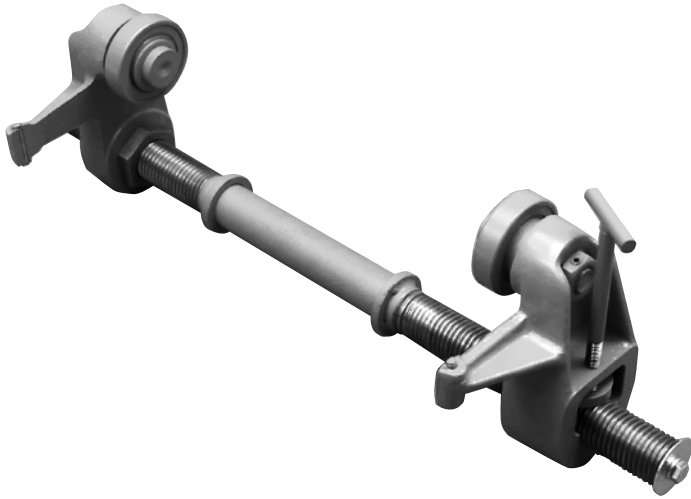

- Designed to work on a horizontal I-beam
- SA-1003 fits flanges 4-10 in. (102-254 mm) wide
- SA-1003-22 fits flanges up to 16 in. (406 mm) wide and 1 3/8 in. (35 mm) thick
- SA-1003-1 Thick Flange Adapter Bracket adapts either beam roller to flanges up to 2 1/4 in. (70 mm) thick. Order two for each SA-1003 roller.

### Key Features:

- Heavy duty steel construction
- Time-tested design
- No tools required for installation
- Built by Spider in the USA

### Notes for use:

- The beam width needs to be known in advance, as the flange width is needed to determine the location of the fixed roller.
- The beam flange should be a consistent width, with no cutouts or notches that would allow the roller to roll off.
- Block or clamp the end of the beam to keep the roller from rolling off using 702067-1 end stop.
- The beam must be level, as rollers do not have a brake.

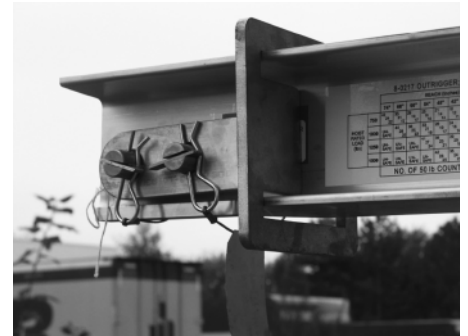

**702067-1 End Stop**

Specifications:	SA-1003	SA-1003-22
Load/Capacity:	1,500 lbs. (680.4 kg)	1,500 lbs. (680.4 kg)
Weight:	12 lbs. (5.5 kg)	12 lbs. (5.5 kg)
Used with:	Flanges 4-10 in. (102-254 mm wide)	Flanges up to 16 in. wide and 1 3/8 in. (35 mm) thick
Construction:	Steel	Steel