

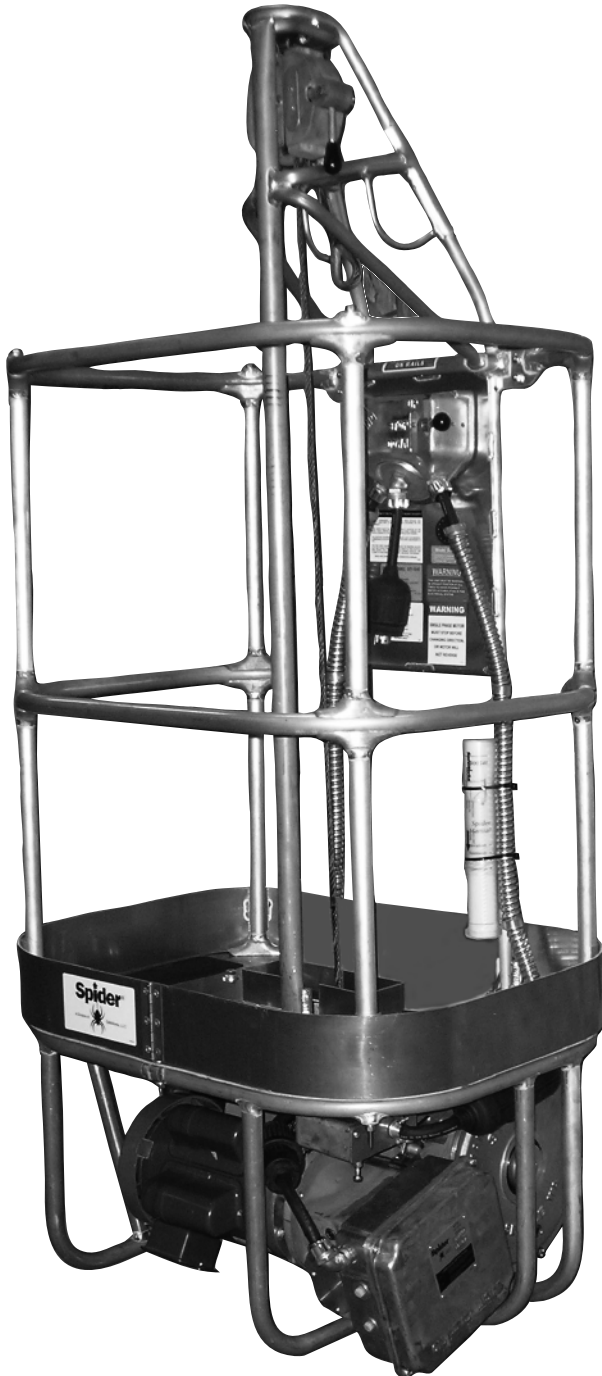

ST-19E Demountable Spider



Self-contained work cage easily disassembles without special tools to pass through a 20 in. (508 mm) diameter opening.

- Bolted, lightweight aluminum frame is ideal for limited access work in boilers, ships, tanks and stacks.
- Built-in overload device and overspeed brake
- Reinforced midair transfer point and wear plates at base
- Optional 2 ft (0.6 m) SA-1052 and 3 ft (0.9 m) SA-1053 flydecks
- **Available in rental fleet and for sale on a special order basis**

Specifications: ST-19E
Gross Load Capacity: 1,000 lbs. (453.6 kg)
Dimensions: 30 x 23 x 70 in. (762 x 584 x 1,778 mm)
Weight: 205 lbs. (93 kg)
Travel Speed: 18 ft/min (5.5 m/min)
Voltage Options: 115V single phase (50 and 60Hz models available)
Wire Rope Capacity: 350 ft (106.7 m)
Wire Rope Size and Construction: 5/16 in. (8 mm) Seale Construction 6 x 19
Construction: Aluminum and steel

For welding installation details, see pages 197-198.

For more information, call: 1-877-774-3370

ST-19E

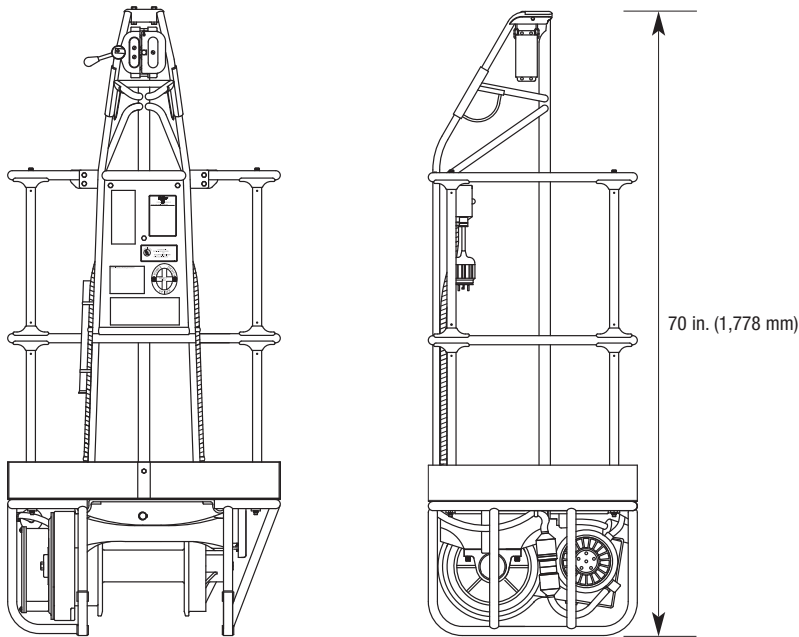

ST-19A

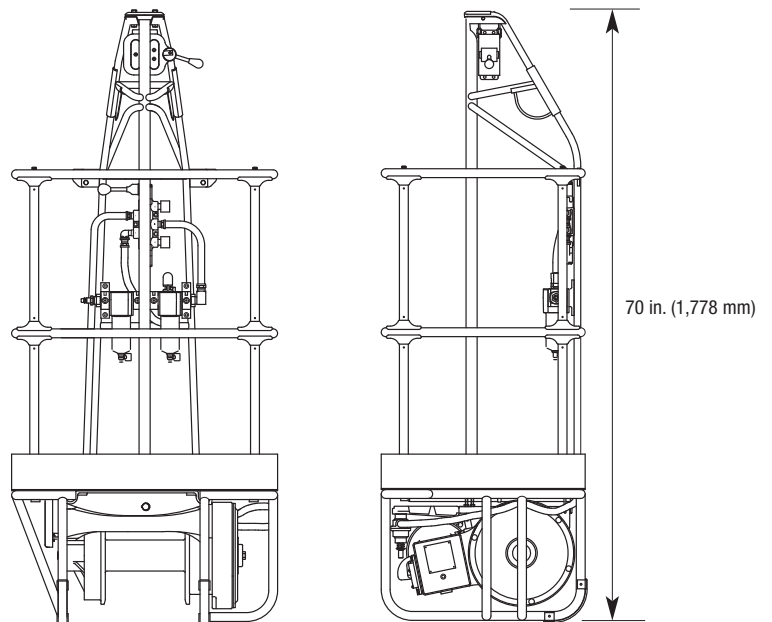

More information online at
www.spiderstaging.com

For more information, call: 1-877-774-3370