



# ST-17 Air Spider

The industry standard for work in refineries, tank farms, shipyards, offshore platforms and heavy construction has been redesigned to meet your needs and simplify your ownership experience - lowering your cost of ownership, improving the reliability of the components, and making it easier to service this product right.

### Key Features:

- Air-powered motor
- Reinforced midair transfer point and wear plates at base
- Winding drum hoist offers safe, efficient operation in hazardous and corrosive environments.
- Paint and blast media on wire rope do not impact operation of unit.
- Reliable vented transmission prohibits entry of corrosive agents for greater durability.
- Constant pressure versa valve ensures complete, immediate stop on release of operating lever.
- Built-in breather vent kit
- Simpler wire rope changes
- Simpler service
- Reusable wear parts
- Fairlead guide replaces steel wire rope guides
  - 2 mating universal pieces extend life 4 times that of prior design.
  - Wear guide that indicates replacement interval
  - Polymer material resists corrosion
  - Retrofittable to prior ST-17/19/180 models
- Tension holder assembly
  - Simple polymer assy
  - Replaces service intensive SA-1077 by reducing number of parts from 44 to just 16
  - Simple test shows when to replace tension blocks
  - Retrofittable to ST-17/19/180 models
- More robust and reliable oiler/filter lubricator assembly
  - Easier mounting
  - More robust mounting brackets
  - Better visual management
  - Improved serviceability from special lubricants that decrease maintenance time for equipment used in harsh industrial environments



*For welding installation details, see pages 197-198.*

### Specifications: ST-17-x-xxx

**Gross Load Capacity:**  
1,000 lbs. (453.6 kg)

**Dimensions:**  
37 x 29 x 72 in. (940 x 737 x 1,829 mm)

**Weight:**  
ST-17: 209 lbs. (94.8 kg)  
ST-17-1: 210 lbs. (95.3 kg)

**Travel Speed:**  
30 ft/min (9.2 m/min)

**Power Requirements:**  
120 psi air @ 60 cfm

**Wire Rope Capacity:**  
ST-17: 350 ft (106.7 m)

**Wire Rope Size and Construction:**  
5/16 in. (8 mm) Seale Construction 6 x 19

**Construction:**  
Aluminum and steel

# ST-17CE

The reliable industrial basket has been modified to meet the European CE standard so it can be used where facility owners require CE certification.

### Additional features include:

- Top limit switch with trip plate
- Lower limit/slack rope sensor with bypass for dereeving unit
- Emergency stop to cut air supply to basket in case of emergency
- Secondary wire rope grab for two-line system

This is a special order product. Call Spider for details.

"I have just received another Spider basket on my offshore rig. I have ordered a Spider basket for every rig I am assigned to and use the Spiders very successfully. My first job offshore was on a spy ship named the Hughes Glomar Explorer in 1974. We were raising a sunken Russian submarine and had 2 Spider baskets onboard the ship for that mission. I just ordered your new ST-17CE - simply great! Thanks for 36 years of working with Spider - it is a great product."

- Glenn T. Clemens, Barge Capt  
West Pealut

**For more information, call: 1-877-774-3370**



**Spider has also developed 8 new variations of the popular ST-17.**

- **ST-17-3-XXX** Aluminum Cage, Thimble
- **ST-17-4-XXX** Aluminum Cage, 18 in. Eye Splice
- **ST-17-5-XXX** Aluminum Cage, Thimble, Arc Guard Kit
- **ST-17-6-XXX** Aluminum Cage, 18 in. Eye Splice, Arc Guard Kit
- **ST-17-7-XXX** SST Cage, Thimble
- **ST-17-8-XXX** SST Cage, 18 in. Eye Splice
- **ST-17-9-XXX** SST Cage, Thimble, Arc Guard Kit
- **ST-17-10-XXX** SST Cage, 18 in. Eye Splice, Arc Guard Kit

'SST' refers to stainless steel frame and fasteners

'XXX' indicates the wire rope length which ranges from 50 ft (15.2 m) to 350 ft (91.4 m) in 50 ft (15.2 m) increments. Call Spider for details.

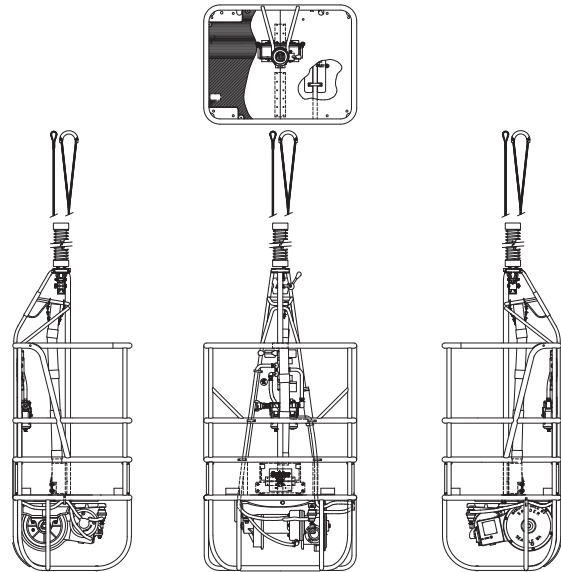
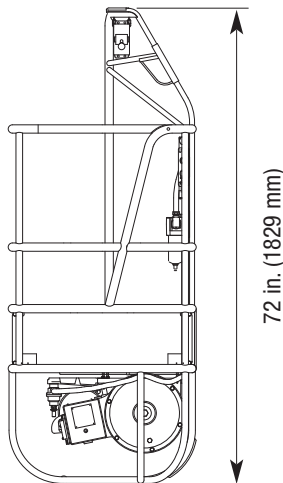
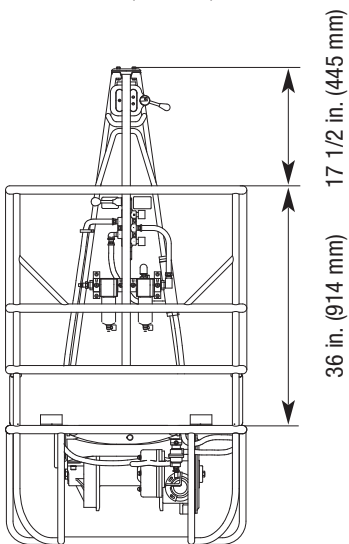
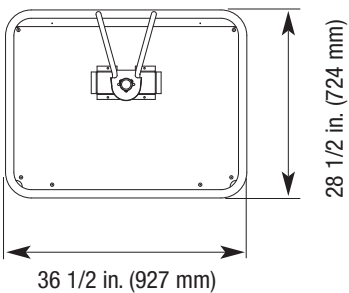

Also available: 702049-1 36 in. (914 mm) whip

**Frequently used accessories:**

- SA-1002 Transfer Chain on page 222.
- SA-1083 Drum Hoist Arc Guard Kit on page 224.
- SA-1051 Flydeck on page 73.

**For more information, call: 1-877-774-3370**

# Take the Spider Test!

Protect your interests by educating yourself before you buy. Ask your supplier to verify their product's quality compared to the **Spider ST-17**.

Key Features	Benefits	Competitive equipment may offer:	Your purchased or rented unit matching ST-17 features	Required by Law
<b>UL Listing</b>	<ul style="list-style-type: none"> <li>Assures design and manufacturing integrity</li> <li>Reduces user liability of non-certified equipment</li> <li>Use complies with OSHA regulations</li> <li><b>UL File #SA-5062 originated, owned and maintained by Spider - verify it at <a href="http://www.UL.com">www.UL.com</a>.</b></li> </ul>	No UL listing		OSHA 1910.28(i)(1) & (g)(3); Hoists must be tested and listed by nationally recognized testing laboratory.
<b>Overspeed brake in drum</b>	<ul style="list-style-type: none"> <li>Stops travel within 12 in. (305 mm) when descent beyond rated speed is sensed</li> <li>Brake also engages during changes in momentum</li> </ul>	No overspeed brake in drum		OSHA 1926(i)(4) requires primary brake and emergency brake which engages automatically when normal descent speed is exceeded.
<b>Full OSHA/ANSI compliance</b>	<ul style="list-style-type: none"> <li>Meets or exceeds the applicable OSHA and ANSI standards for suspended scaffolds</li> </ul>	Does not meet OSHA/ANSI		Yes
<b>Inspection port in transmission</b>	<ul style="list-style-type: none"> <li>Permits visual inspection of gears for wear without disassembling the transmission</li> </ul>	No inspection port in transmission		No. Maintenance per manufacturer's recommendation is required.
<b>Solid aluminum bar stock tripod and aluminum chain guards</b>	<ul style="list-style-type: none"> <li>Adds strength for mid-air transfers</li> <li>Eliminates galvanic corrosion of the tripod, increasing the life of the hoist in corrosive environments</li> </ul>	Hollow tubing used for tripod and steel (dissimilar material) used for chain guards		No
<b>New original qualified parts</b>	<ul style="list-style-type: none"> <li>Ensures smooth operation and increases durability</li> </ul>	Parts are remanufactured in hoists marketed as new.		No. In many jurisdictions, Uniform Commercial Code prohibits sale of remanufactured products as new.
<b>Bracing design on back side of unit allows easy access</b>	<ul style="list-style-type: none"> <li>Unencumbered access between mid rail and top rail makes wire rope installation easier.</li> </ul>	Bracing on back side same as front side – makes access difficult		Yes. Employers are required to provide a safe work place.
<b>Engineered guide ring saves time</b>	<ul style="list-style-type: none"> <li>Less wear on wire rope reduces cost.</li> <li>Engineered polymer guide disc has built-in wear gauge to identify replacement interval.</li> <li>Reversible design doubles assembly life.</li> <li>Large opening eliminates disassembly during wire rope replacement.</li> </ul>	Guide ring assembly only includes one steel guide ring, which increases wear.		No
<b>Barbed fittings</b>	<ul style="list-style-type: none"> <li>More secure, durable and safer form of hose termination</li> <li>Eliminates cutting hazard and untimely disconnects</li> </ul>	Hose clamps		No. Some refineries and other facility owners prohibit the use of hose clamps.
<b>Industry leading manufacturer</b>	<ul style="list-style-type: none"> <li>Product backed by one of the strongest product liability insurance coverages in the industry</li> <li>Certificate of General Liability Coverage provided within 24 hours of request</li> <li>Spider introduced the drum hoist to the industry in 1946 and has operated continuously for over 65 years.</li> <li>Product design updates, as released in 2002 and 2008</li> </ul>	Check before you buy.		No. Relying on uninsured or under-insured vendors increases risk and can affect your insurance rates.

The ST-17 is the finest quality work basket in the world and is a result of years of improvements, primarily from customer feedback.

## All Hoists Are Not *RE*created Equally

Don't be fooled. There are a lot of imitators out there but only one Spider. Many have attempted to replicate our ST-17 work basket, but copy cats don't come close to the original. Protect your interests by educating yourself before you buy or rent. Here are a few things that make Spider's ST-17 the one and only...Don't settle for anything less than the original Spider ST-17 work basket.

**Fact:** The Spider ST-17 is THE invention that started the powered access industry in the 1940s, forever changing the way work at high elevations is accessed.

**Fact:** Production of the ST-17 has been steady since the 1940s, deeming the production of this hoist the longest running in the industry.

**Fact:** Only Spider's drum hoists are UL listed.

**Fact:** Spider's 25 operation centers in the Americas are the only locations where hoists are repaired using a 116 point checklist and genuine OEM (original equipment manufacturer) parts by factory-trained qualified technicians working under expert supervision.

**Fact:** Spider utilizes a coordinate measuring machine that verifies production standards for the close tolerance mechanical components of our hoists, so you can be certain every part has met exacting specifications. UL employees personally inspect our production regularly to assure compliance to the tested product UL listed for safety and reliability. See why UL matters below.

**Fact:** Several ST-17s that were produced over fifty years ago, including our serial number TA-0112 built in 1950, are still in our rental fleet today. That's how we define reliability.

**Fact:** Over the past 65 years, Spider has continuously updated, improved and modified the ST-17 model to improve ease of use and serviceability and to meet current regulation requirements.

**Fact:** Spider's ST-17 and the work our factory-trained certified technicians perform is backed by the strongest liability insurance in the industry - \$21 million in coverage by A15+ rated AIG.



### Spider invests in UL and CUL Certification for your Safety

Spider designs, engineers, builds and tests its hoists in accordance with the Underwriters Laboratories UL1323 standard for hoists as required by OSHA under OSHA 1910.28(i)(1) &(g)(3) and 1926.451(d)(13). Employers are required under OSHA to use hoists tested by both a Nationally Recognized Testing Laboratory and a Qualified Testing Laboratory, depending on which code section applies. Underwriters Laboratory (UL) is one of three Nationally Recognized Testing Laboratories accredited to test to the UL1323 standard.

**Spider makes the choice** to list our hoists with UL® because it provides **Spider equipment users** equipment that is **safer** than products listed by other labs. This gives Spider customers **peace of mind**. UL® interprets the UL1323 test standard with the intent from which this code was written and rigorously applies the UL1323 code to its initial performance testing protocol and its ongoing certification program.



Not all manufacturers invest in UL listing. **Our hoists are UL® listed.** To verify the listing status, see that SafeWorks earned its UL Classification and continues to maintain this listing in file TUFV.SA5062 at [www.UL.com](http://www.UL.com).

Examiners employed by Underwriters Laboratories regularly inspect our hoists during production in our factories to verify consistent sustained production of the products as designed and originally tested and listed. This drives a **safer, more reliable product for our users.**

More information online at  
[www.spiderstaging.com](http://www.spiderstaging.com)

**For more information, call: 1-877-774-3370**