

Fold-Up Work Cage (P-00130)



6 ft (1.8 m) Internal Universal Mount Work Cage

- Steel construction
- Compatible with SC1000, Zmac/1000®, SC40, SC30 and most brands of traction hoist

Key features:

- Lightweight
- Compact
- Easy assembly
- Powder-coated to prevent rust and lengthen product life
- Folds up for easy storage
- Mesh floors allow water to escape rather than collect in the cage—eliminates possibility of warping and reduces potential electrical problems
- Includes roller bumpers and attached tail boards that do not need to be disassembled before storage
- Passes through a 24 in. (610 mm) diameter opening or through a 13 x 20 in. (330 x 508 mm) rectangular opening
- The toe boards are permanently attached.
- The gooseneck has a roller system for the wire rope guide.
- The rollers are attached with mounted brackets instead of U-bolts.

Specifications:	Gross Load Capacity:	Dimensions:		Weight:	Maximum Live Load:
		Fully Expanded	Collapsed		
P-00130-1 8 ft. (2.4 m) Internal Mount	1,000 lbs. (453.6 kg)	96 x 19 7/8 x 81 1/2 in. (2440 x 505 x 2070 mm)	14 x 19 7/8 x 88 5/8 in. (356 x 505 x 2250 mm)	163 lbs. (73.9 kg)	500 lbs. (226.8 kg)
P-00130-2 8 ft. (2.4 m) External Mount	1,000 lbs. (453.6 kg)	96 x 25 1/8 x 82 5/32 in. (2440 x 638 x 2090 mm)	14 x 25 1/8 x 88 5/8 in. (356 x 638 x 2250 mm)	168 lbs. (76.2 kg)	500 lbs. (226.8 kg)
P-00130-3 6 ft. (1.8 m) Internal Mount	1,000 lbs. (453.6 kg)	72 x 19 7/8 x 81 1/2 in. (1830 x 505 x 2070 mm)	14 x 19 7/8 x 81 1/2 in. (356 x 505 x 2070 mm)	151 lbs. (68.5 kg)	500 lbs. (226.8 kg)
P-00130-4 6 ft. (1.8 m) External Mount	1,000 lbs. (453.6 kg)	72 x 25 1/8 x 82 5/32 in. (1830 x 638 x 2090 mm)	14 x 25 1/8 x 82 5/32 in. (356 x 638 x 2090 mm)	156 lbs. (70.8 kg)	500 lbs. (226.8 kg)
P-00130-5 4 ft. (1.2 m) External Mount	1,000 lbs. (453.6 kg)	48 x 25 1/8 x 82 5/32 in. (1220 x 638 x 2090 mm)	14 x 25 1/8 x 82 5/32 in. (356 x 638 x 2090 mm)	132 lbs. (59.9 kg)	500 lbs. (226.8 kg)

For welding installation details, see pages 197-198.

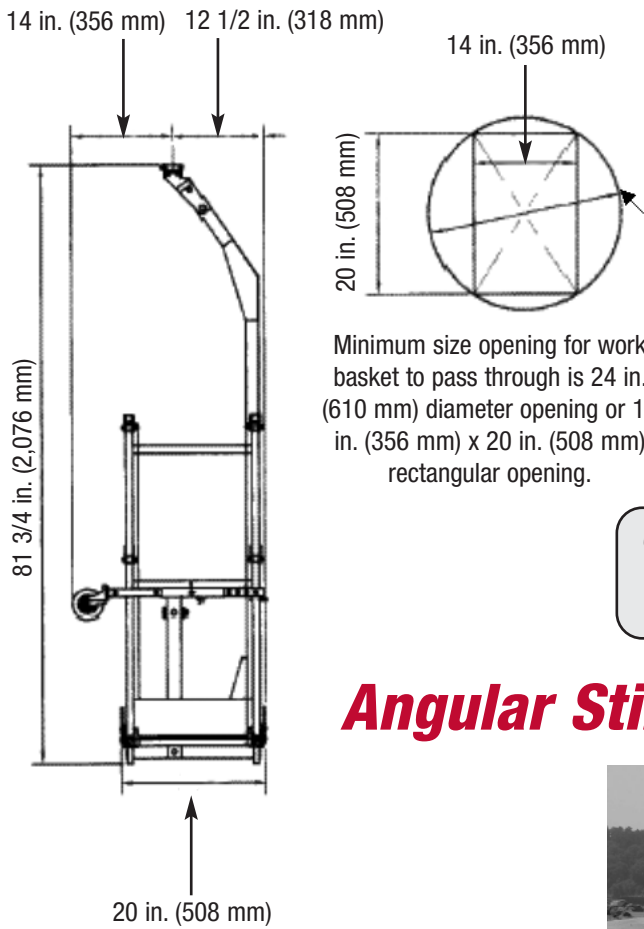

Minimum size opening for work basket to pass through is 24 in. (610 mm) diameter opening or 14 in. (356 mm) x 20 in. (508 mm) rectangular opening.



6 ft (1.8 m) Internal Universal Mount



6 ft (1.8 m) Internal Universal Mount, shown folded for storage or opening

6 ft. (1.8 m) Internal Universal Mount Work Cage is depicted, but various models are available. See specifications on page 194 or call Spider for details: 1-877-774-3370.

Angular Stirrups (P-00247-201)

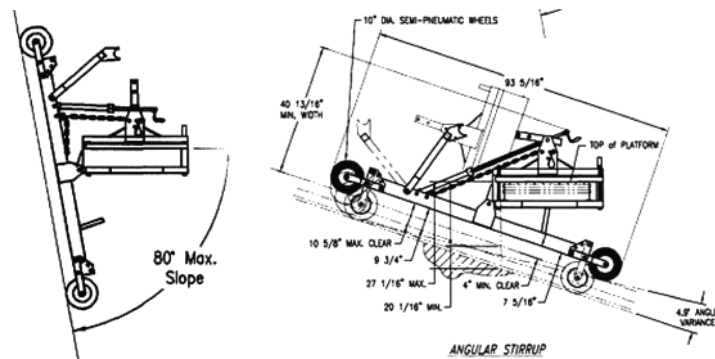
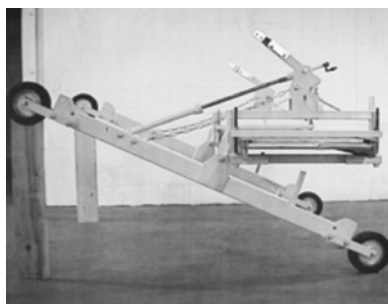
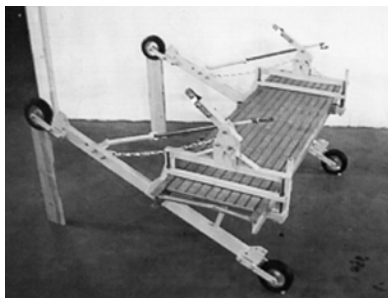

Angular Stirrups can be used with mod platforms. Contact your Spider professional for more details.

**More information online at
www.spiderstaging.com**

For more information, call: 1-877-774-3370