

NOTES:

101. USE OF SUSPENDED SCAFFOLDING SHALL COMPLY WITH OSHA 29 CFR 1926.451(f) AND ANY APPLICABLE LOCAL REGULATIONS.

102. ALL PERSONNEL ON SUSPENDED SCAFFOLDING SHALL HAVE AN INDEPENDENT FALL ARREST SYSTEM THAT COMPLIES WITH OSHA 29 CFR 1926.451(g) AND ANY APPLICABLE LOCAL REGULATIONS.

103 SUPPORTING STRUCTURE SHALL HOLD 4 TIMES LOADS SHOWN WITHOUT FAILURE.

104 REFER TO SC1000 TRACTION HOIST OPERATIONS MANUAL 9961 FOR SPECIFIC INSTRUCTIONS FOR OPERATING THE SC1000 HOIST.

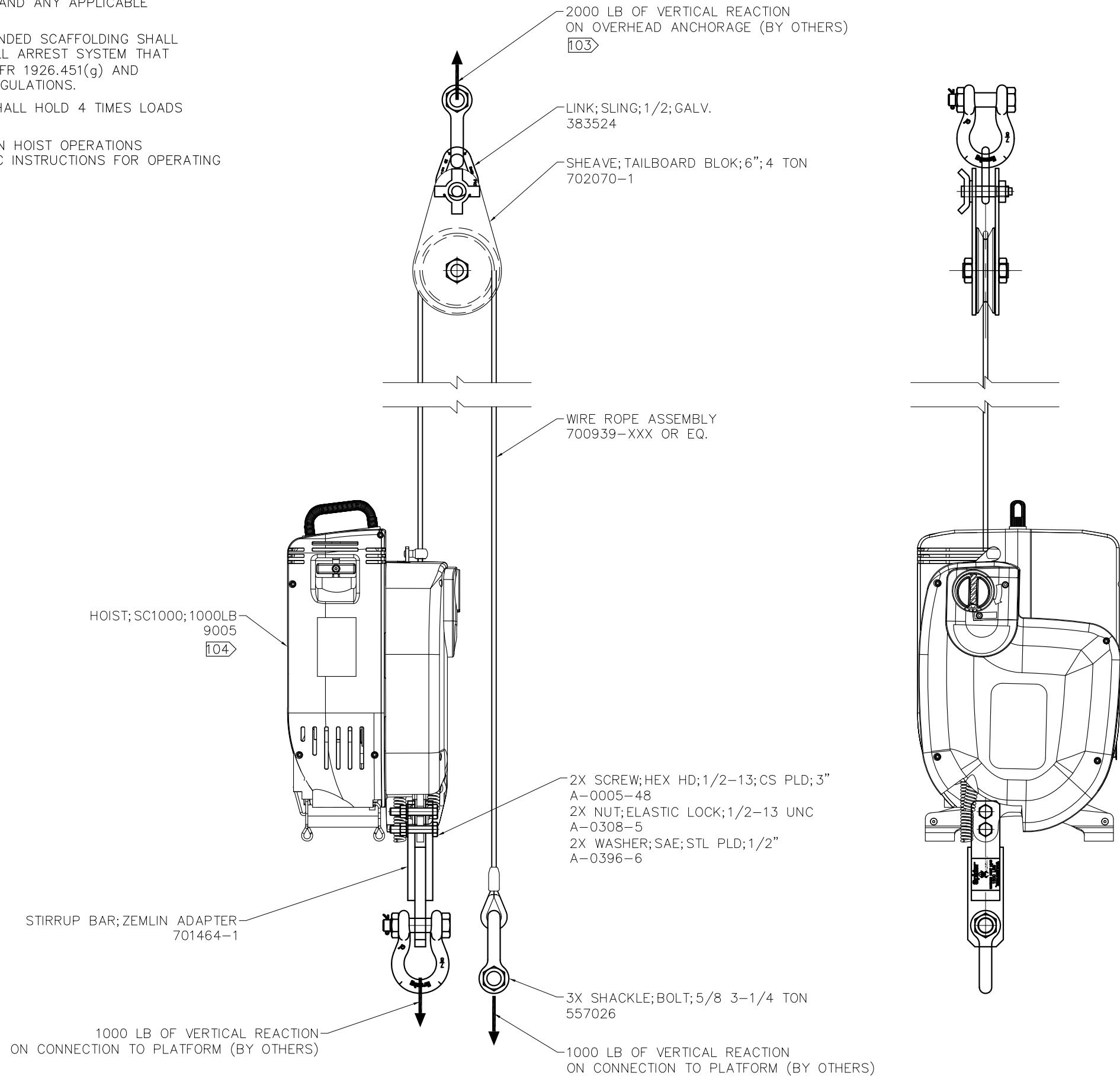

REV 1	ECO	BETA RELEASED	DATE 12-04-2013	BY TSM	CK JTA
 A Division of SafeWorks, LLC 365 UPLAND DRIVE SEATTLE, WASHINGTON 98188			MATERIAL:		
			THIS DRAWING IS THE PROPERTY OF SAFEWORKS, LLC. AND IS NOT TO BE COPIED OR REPRODUCED WITHOUT THE WRITTEN CONSENT OF SAFEWORKS, LLC.		
DRAWN BY TSM			DATE 12-04-2013		
ENG JTA			SCALE D 3"=1'-0"		
TITLE			2-PART HOIST ROPE		
DRAWING NUMBER			GA1035		
			1 OF 1		