

NOTES:

- 101. USE OF SUSPENDED SCAFFOLDING MUST COMPLY WITH OSHA 29 CFR 1926.451(f) AND ANY APPLICABLE LOCAL REGULATIONS.
- 102. ALL PERSONNEL ON SUSPENDED SCAFFOLDING MUST HAVE AN INDEPENDENT FALL ARREST SYSTEM THAT COMPLIES WITH OSHA 29 CFR 1926.451(g) AND ANY APPLICABLE LOCAL REGULATIONS.
- 103. SUSPENDED SCAFFOLD RIGGING AND TIEBACKS MUST COMPLY WITH OSHA 29 CFR 1926.451(a) AND 1926.451(d) AND ANY APPLICABLE LOCAL REGULATIONS.
- 104. USER SHALL FOLLOW DIRECTIONS FOR ASSEMBLY AND USE AS SHOWN ON LABEL P/N 702279
- 105. SEE TABLE FOR AMOUNT OF COUNTERWEIGHT REQ'D AND RESULTANT FRONT LEG LOADS.
- 106. SUPPORTING STRUCTURE MUST HOLD LOADS SHOWN WITHOUT FAILURE. LOADS SHOWN WERE CALCULATED AT 4 TIMES HOIST RATED CAPACITY.
- 107. FOR REACHES NOT LISTED THE AMOUNT OF COUNTERWEIGHT CAN BE CALCULATED USING THE EQUATION $C=(4xLxR)/B$ THE VERTICAL REACTION AT THE FULCRUM CAN BE CALCULATED BY USING THE EQUATION $F=(4xL+C)/2$
- 108. SEE DRAWINGS GA1001, GA1002 & GA1003 FOR DETAILS OF TYPICAL PLATFORM ASSEMBLES
- 109. TYPICAL TIEBACK DETAILS ON GA1014, GA1015 & GA1016

		"R" REACH (INCHES)									
		96"	90"	84"	80"	76"	72"	66"	64"	60"	54"
RATED LOAD OF HOIST (LB) "L"	1000	39	35	32	30	28	26	-	-	-	-
	1250	UN-SAFE	UN-SAFE	UN-SAFE	UN-SAFE	35	33	29	28	26	-
	1500	UN-SAFE	UN-SAFE	UN-SAFE	UN-SAFE	UN-SAFE	UN-SAFE	UN-SAFE	34	31	27
		NO. OF 50 LB COUNTERWEIGHTS "N"									

COUNTERWEIGHT TABLE

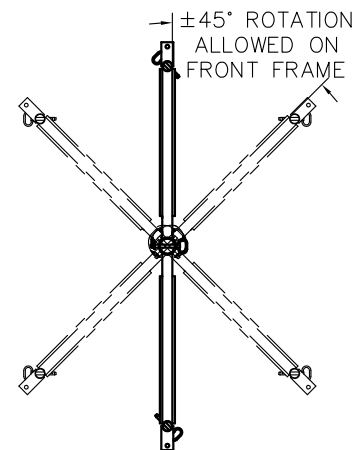

		"R" REACH (INCHES)									
		96"	90"	84"	80"	76"	72"	66"	64"	60"	54"
RATED LOAD OF HOIST (LB) "L"	1000	5950	5750	5600	5500	5400	5300	-	-	-	-
	1250	UN-SAFE	UN-SAFE	UN-SAFE	UN-SAFE	6750	6650	6450	6400	6300	-
	1500	UN-SAFE	UN-SAFE	UN-SAFE	UN-SAFE	UN-SAFE	UN-SAFE	UN-SAFE	7700	7550	7350

VERTICAL REACTION AT FULCRUM "F" (LB/LEG)

		"R" REACH (INCHES)									
		96"	90"	84"	80"	76"	72"	66"	64"	60"	54"
RATED LOAD OF HOIST (LB) "L"	1000	975	875	800	750	700	650	-	-	-	-
	1250	UN-SAFE	UN-SAFE	UN-SAFE	UN-SAFE	875	825	725	700	650	-
	1500	UN-SAFE	UN-SAFE	UN-SAFE	UN-SAFE	UN-SAFE	UN-SAFE	UN-SAFE	850	775	675

VERTICAL REACTION AT COUNTERWEIGHT "C" (LB/CASTER)

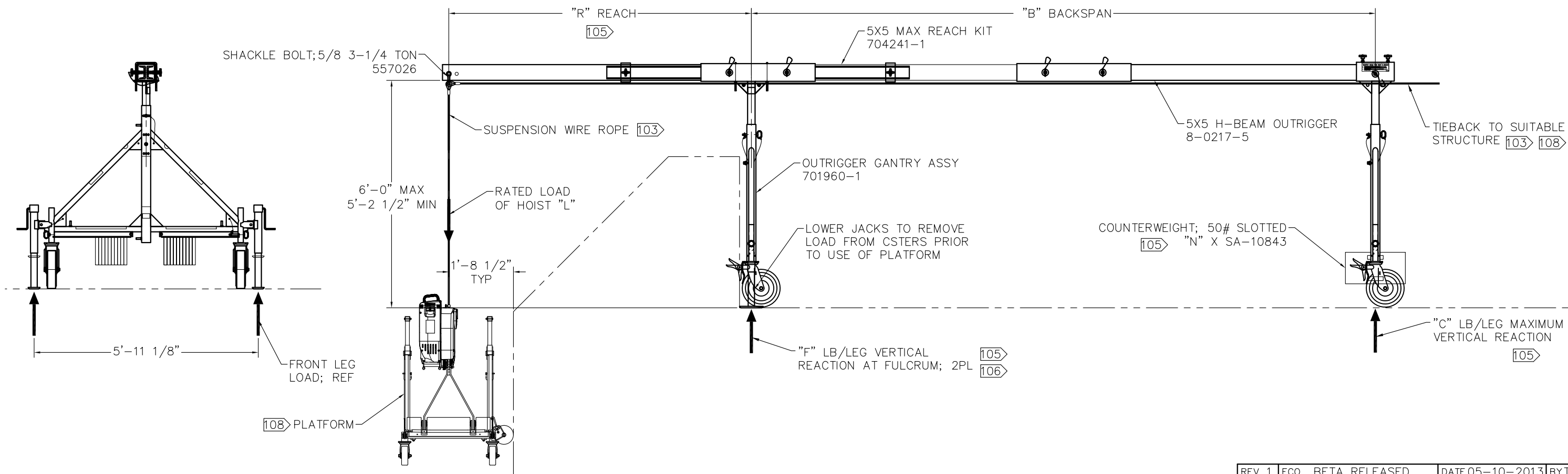

SPIDER ROLLING GANTRY WITH 5X5 OUTRIGGER WITH MAX REACH KIT

REV 1	ECO	BETA RELEASED	DATE 05-10-2013	BY TSM	CK JTA
 A Division of SafeWorks, LLC			MATERIAL:		
365 UPLAND DRIVE SEATTLE, WASHINGTON 98188			THIS DRAWING IS THE PROPERTY OF SAFEWORKS, LLC. AND IS NOT TO BE COPIED OR REPRODUCED WITHOUT THE WRITTEN CONSENT OF SAFEWORKS, LLC.		
DRAWN BY TSM		DATE 3-21-13		TITLE 5X5 MAX REACH KIT ROLLING GANTRY	
ENG JTA		SCALE D 3/4":1'-0"		DRAWING NUMBER GA1017	
					1 OF 1