

## DATA & SPECIFICATION SHEET ROSLIFT 400 MOTORISED CLIMBING TROLLEY

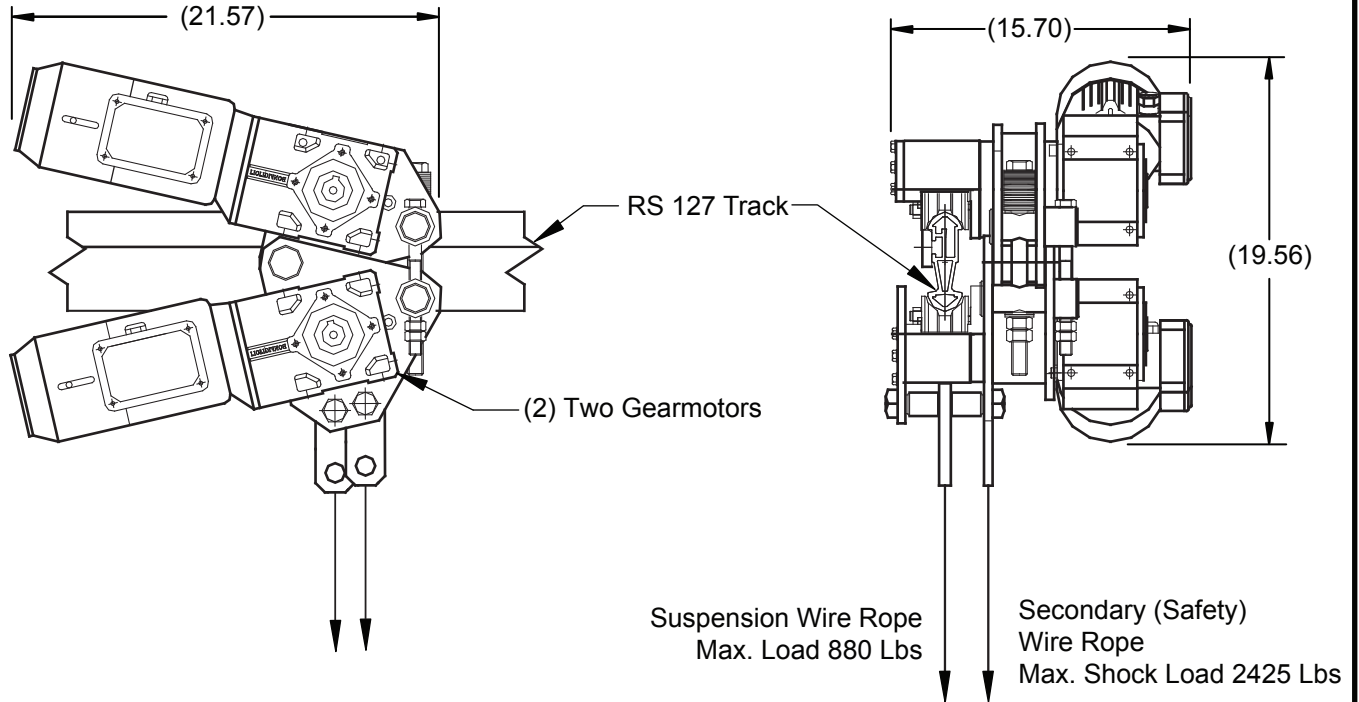

### Description:

Roslift 400 is a special climbing trolley designed to be used on a monorail to suspend a platform. Roslift 400 can climb any slope, even vertically. The rated load is 880 Lbs. The Roslift trolley can only be used on Rostek RS127-track. A Roslift 400 has two power packs and it works on the friction between its wheels and the aluminium track. Roslift is designed to work safely even on wet or frosty tracks thus enabling around the year service in most weather conditions.

### Technical Data :

2 power packs : Bonfiglioli Italy A102  
electric motors 0.37 kW each  
400 Volts, 3-phase  
rated load 880 Lbs.  
self weight of Roslift approx. 121 Lbs.  
built-in motorbrake  
built in double overspeed devices

Spider Permanent Installations  
365 Upland Drive  
Tukwila, WA 98188 USA

Phone: (206) 575-6445 / Fax: (206) 575-6240  
E-mail: [spiderpi@safeworks.com](mailto:spiderpi@safeworks.com)  
Internet: [www.SpiderStaging.com/pi](http://www.SpiderStaging.com/pi)

THIS DATA SHEET AND ALL REPRODUCTIONS ARE THE PROPERTY OF SPIDER® ALL DIMENSIONS AND FIGURES SHOWN ARE FOR GENERAL INFORMATION ONLY AND SHOULD BE CONFIRMED AND PERMISSION OBTAINED FROM SPIDER BEFORE BEING USED FOR DESIGN OR CONSTRUCTION PURPOSES. ALL INFORMATION IS SUBJECT TO CHANGE WITHOUT NOTICE. SPIDER IS A DIVISION OF SAFEWORKS™ LLC